

**SoCare®**

**SCB-HT Series**

Slew Rings



# SCB-HT Series

## Introduction

SCB-HT bearings have the same configuration as the SCB-HS bearing. Produced with a larger cross section ring and larger diameter rolling elements. OD size range : 36"-66"  
Increased capacity over the SCB-HS bearing.

## Construction

- Deep groove gothic arch
- 4 point contact
- Sealed
- Ring Configuration:
  - Non geared
  - External gear
  - Internal gear
- Geared rings have tapped holes
- Non geared rings have thru holes
- Gear detail:
  - Involute Stub
  - 20 deg
  - AGMA8 Class (Contact SoCare® if you need higher precision AGMA8-AGMA10 level, AGMA11 would be available for SoCare® which is subject to the bearing design)
  - .005"-.025" allowable backlash
- Grease fittings for lubrication

## Applications

- Rotary table
- Lifts
- Material handling
- Derricks
- Rotators
- Stretch wrap equipment
- Crane



## No Gear

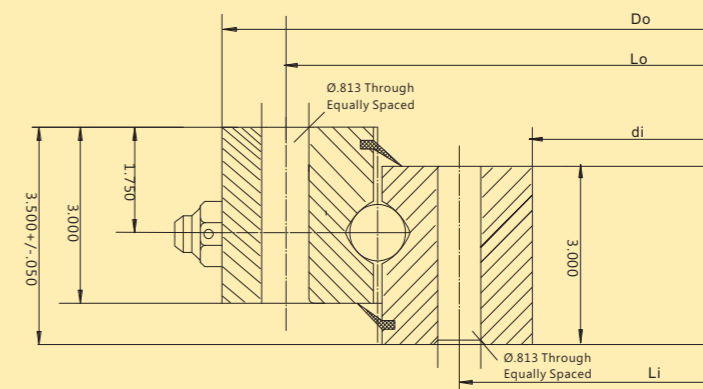

SOCARE® No.	KAYDON® No.	OUTLINE DIMENSIONS(IN) AND WEIGHT(LBS)				OUTER RING		INNER RING		Gear Data INV.STUB,α=20°				Moment Rating Crm (ft-lbs)
		Do	di	G(LBS) Approx.	Lo	no	Li	ni	D2 (in)	Pd (in)	Z2	Fz (lbs)		
SCB-HT914	HT10-30P1Z	36.000	24.000	447	33.250	24	26.750	30					340,000	
SCB-HT1066	HT10-36P1Z	42.000	30.000	521	39.250	28	32.750	32					395,700	
SCB-HT1219	HT10-42P1Z	48.000	36.000	628	45.250	32	38.750	36					457,000	
SCB-HT1371	HT10-48P1Z	54.000	42.000	719	51.250	36	44.750	40					517,900	
SCB-HT1524	HT10-54P1Z	60.000	48.000	809	57.250	40	50.750	44					578,400	
SCB-HT1676	HT10-60P1Z	66.000	54.000	865	63.250	44	56.750	48					638,800	

Contact SoCare® about custom features, configurations and construction. (mounting holes, materials, coating, internal clearance)

## Internal Gear

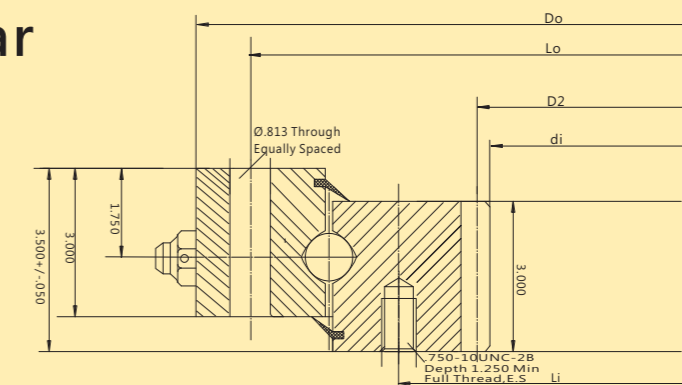

SOCARE® No.	KAYDON® No.	OUTLINE DIMENSIONS(IN) AND WEIGHT(LBS)				OUTER RING		INNER RING		Gear Data INV.STUB,α=20°				Moment Rating Crm (ft-lbs)
		Do	di	G(LBS) Approx.	Lo	no	Li	ni	D2 (in)	Pd (in)	Z2	Fz (lbs)		
SCB-HTN914	HT10-30N1Z	36.000	24.160	411	33.250	24	27.250	30	24.800	2.5	62	21,783	340,000	
SCB-HTN1066	HT10-36N1Z	42.000	30.160	517	39.250	28	33.250	32	30.800	2.5	77	21,195	395,700	
SCB-HTN1219	HT10-42N1Z	48.000	36.160	580	45.250	32	39.250	36	36.800	2.5	92	20,819	457,000	
SCB-HTN1371	HT10-48N1Z	54.000	42.160	689	51.250	36	45.250	40	42.800	2.5	107	20,548	517,900	
SCB-HTN1524	HT10-54N1Z	60.000	48.160	775	57.250	40	51.250	44	48.800	2.5	122	20,344	578,400	
SCB-HTN1676	HT10-60N1Z	66.000	54.160	842	63.250	44	57.250	48	54.800	2.5	137	20,185	638,800	

Contact SoCare® about custom features, configurations and construction. (mounting holes, materials, coating, internal clearance)





# External Gear

HT LOAD RATINGS\*\*

\*\*Ratings based on bearing capability, consult SoCare® engineering to ensure design criteria.

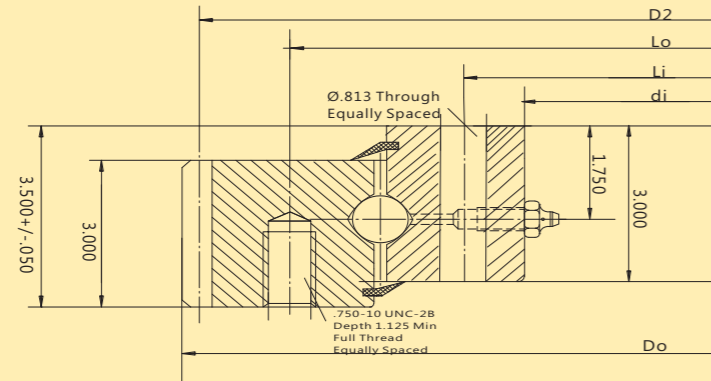

SOCARE® No.	KAYDON No.	OUTLINE DIMENSIONS (IN) AND WEIGHT (LBS)				OUTER RING				INNER RING				Gear Data INV. STUB, $\alpha=20^\circ$				Moment Rating Crm (ft-lbs)
		Do	di	G(LBS) Approx.		Lo	no	Li	ni	D2 (in)	Pd (in)	Z2	Fz (lbs)					
SCB-HTE910	HT10-30E1Z	35.840	24.000	398		32.750	24	26.750	30	35.200	2.5	88	18,393			340,000		
SCB-HTE1062	HT10-36E1Z	41.840	30.000	481		38.750	28	32.750	32	41.200	2.5	103	18,608			395,700		
SCB-HTE1215	HT10-42E1Z	47.840	36.000	562		44.750	32	38.750	36	47.200	2.5	118	18,772			457,000		
SCB-HTE1367	HT10-48E1Z	53.840	42.000	660		50.750	36	44.750	40	53.200	2.5	133	18,901			517,900		
SCB-HTE1519	HT10-54E1Z	59.840	48.000	742		56.750	40	50.750	44	59.200	2.5	148	19,005			578,400		
SCB-HTE1672	HT10-60E1Z	65.840	54.000	800		62.750	44	56.750	48	65.200	2.5	163	19,090			638,800		

Contact SoCare® about custom features, configurations and construction. (mounting holes, materials, coating, internal clearance)

